



## 70,000 Grain Water Softener

The North Star NST70ED1 Water Softener is NSF certified to reduce contaminants and deliver soft water to households of any size, and the North Star company offers competitive value to installers and homeowners alike. Its U.S.-based customer service team is ready to assist with any needs, while its 100 years of water treatment innovation has led to AutoSense<sup>™</sup> Technology, which learns in-home water patterns to optimize salt, water, and regeneration frequency.

### FEATURES

- AutoSense<sup>™</sup> Technology learns water usage patterns to optimize water use and regeneration frequency
- Utilizes reverse flow regeneration, proven to be the most effective way to clean the resin bed
- Max grain capacity of 70,300 for any household size
- Reduces up to 19 ppm of ferrous (clear water) iron
- Ultra High-flow 1" valve for maximum water pressure Low salt monitor
- Inner tank light
- Installation kit includes custom fit bypass valve



REDUCES  
SEDIMENT



19 PPM CLEAR WATER  
IRON REDUCTION



HOUSEHOLD SIZE  
1-6+ PEOPLE



# WATER SOFTENER

## 70,000 GRAIN

### NST70ED1

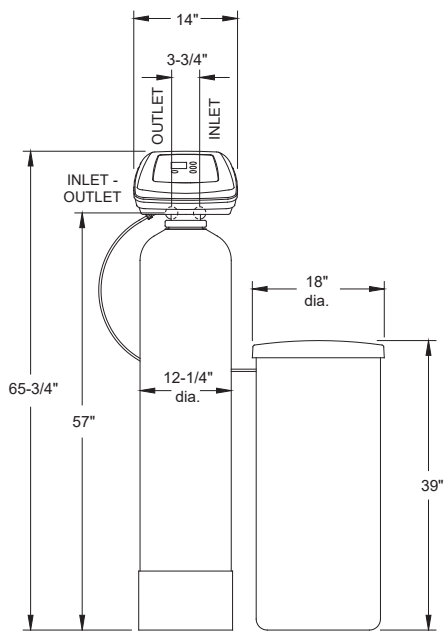

#### SPECIFICATIONS

Model Number	NST70ED1
Part Number	7366457
Household Size	1-6+ people
Max. Capacity (grains)	70,000
Resin (cu. ft)	1.94
Standard Connection Size	1" NPT
Valve	1" valve; up to 1 1/4" plumbing
Connection Size	1" male pipe thread
Rated Service Flow Rate (gpm)	13.5
Intermittent Flow Rate (gpm @ 30 psi drop)	21
Clear Water Iron Reduction (ppm)	19
Electronic Demand	Yes
Max. Efficiency (per minimum salt dose)	5,080 @ 4.1 lbs
Dimensions	Resin Tank and Electronics H 65 3/4" X W 14" Brine Tank H 39" X W 18"
NSF Certification (NSF/ANSI standard)	NSF/ANSI 44, NSF/ANSI/CAN 372, CSA B483.1

#### WARRANTY

**1 year** on all parts | **5 year** on electronics and valves | **10 year** on tanks



Systems tested and certified by NSF International against NSF/ANSI Standard 44 for hardness reduction and efficiency, and certified to NSF/ANSI/CAN Standard 372.



Systems tested and certified by the Water Quality Association against CSA B483.1.

## FOR MORE INFORMATION

### EMAIL

[info@northstarwater.com](mailto:info@northstarwater.com)

### VISIT

[www.northstarwater.com](http://www.northstarwater.com)

## WARRANTY

Warrantor guarantees, to the original owner, that for a period of one (1) year from the date of purchase, all parts will be free from defects in materials and workmanship and will perform their normal functions. For a period of ten (10) years from the date of purchase, the salt storage tank and fiberglass mineral tank will not rust, corrode, leak, burst or in any other manner, fail to perform their proper functions. For a period of five (5) years from the date of purchase, the electronic control board and valve body will be free of defects in materials and workmanship and will perform their normal functions. If, during such respective period, a part proves to be defective, Warrantor will ship a replacement part directly to your home, without charge.