



## 20" Large Capacity Opaque Housing Whole Home Filtration System

The North Star NS9002 20" Large Capacity Opaque Housing is the strong, economical choice for residential homes. With multiple filter options and NSF certified performance, this system can reduce chlorine taste & odor for better-tasting water and sediment to protect the home. North Star's 100 years of expertise in water treatment will ensure top-notch performance and a responsive, U.S.-based customer service team- will offer reliable assistance for any inquiries or needs.

### FEATURES

- Mounting bracket and pressure release button for quick filter changes
- Designed for homes with up to 1" plumbing
- Compatible with most major brands of universal 20" Large Capacity whole home filters
- Compatible with North Star filters: NS9172 & NS9252 (filter not included)
- Includes: sump wrench, bracket, screws, installation guide

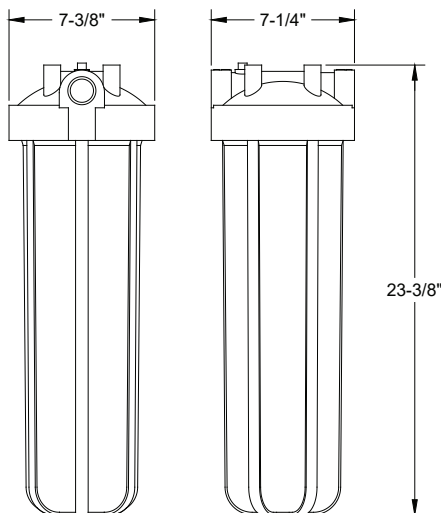

### SPECIFICATIONS

Part Number	7358462
Inlet - Outlet: 3/4"	1" FNPT
Operating Temperature	40-100°F / 5-38°C
Operating Pressure	40-100psi / 275-690kPa
Product Dimensions	(H x W) 23.5" x 7.25"
Uses Filter Size (H x W)	20" x 4.5"
NSF Certification (NSF/ANSI Standard)	42 & 372

### WARRANTY

**1 year** parts warranty

# 20" LARGE CAPACITY OPAQUE HOUSING

WHOLE HOME

NS9002

## 20" STANDARD & LARGE CAPACITY FILTERS



### NSF Certified

- Under NSF/ANSI 42
- Under NSF/ANSI/CAN 372

**Universal Fit:** Fits most major brands of whole home housings

**Grooved:** Provides more surface area and greater capacity

**Carbon Block:** Improves taste and odor of drinking water

### SPECIFICATIONS

Model Number	NS9252	NS9172
Part Number	7358404	7358218
Description	Grooved	Carbon Block
Dimensions	20" x 4.5"	20" x 4.5"
Micron Rating	25	25
Flow Rate (gpm)	50	25
Max Water Temperature	140°F/60°C	100°F/40°C
Filter Life	3 Months	3 Months
Compatible with Systems	NS9002	NS9002

### CONTAMINANT REDUCTION

Sediment - Sand, Dirt, Rust	•	•
Chlorine Taste & Odor		•



System tested and certified by  
NSF International against NSF/ANSI  
Standards 42.

**FOR MORE INFORMATION**

[www.northstarwater.com](http://www.northstarwater.com)

### ONE YEAR LIMITED WARRANTY ON WHOLE HOME WATER FILTER SYSTEM (except filter cartridges)

Warrantor guarantees, to the original owner, that the Whole Home Water Filter System, when installed and maintained in accordance with the instructions, will be free from defects in materials and workmanship for a period of one (1) year from the date of purchase. If, within the first year, a part proves, after inspection, to be defective, Warrantor will, at its sole option, either replace or repair the part without charge except normal shipping and installation charges. Labor to maintain the equipment is not part of the warranty. Filters, which are expendable, are not covered by the warranty.