

10" Large Capacity Opaque Housing Whole Home Filtration System

The North Star NS900 10" Large Capacity Opaque Housing is the strong, economical choice for residential homes. With multiple filter options and NSF certified performance, this system can reduce chlorine taste & odor for better-tasting water and sediment to protect the home. North Star's 100 years of expertise in water treatment will ensure top-notch performance and a responsive, U.S.-based customer service team- will offer reliable assistance for any inquiries or needs.

FEATURES

- Mounting bracket and pressure release button for quick filter changes
- Designed for homes with up to 1" plumbing
- Compatible with most major brands of universal Large Capacity whole home filters
- Compatible with North Star filters: NS917, NSF917, NS905, NS925 & NS950 (filter not included)
- Includes: sump wrench, bracket, screws, installation guide

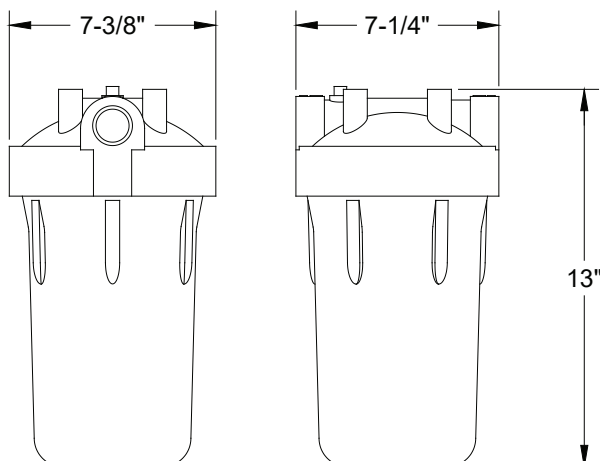

SPECIFICATIONS

Part Number	7358454
Inlet - Outlet: 3/4"	1" FNPT
Operating Temperature	40-100°F / 5-38°C
Operating Pressure	40-100psi / 275-690kPa
Product Dimensions	(H x W) 13.25" x 7.25"
Uses Filter Size (H x W)	10" x 4.5"
NSF Certification (NSF/ANSI Standard)	42 & 372

WARRANTY

1 year parts warranty

10" LARGE OPAQUE HOUSING

WHOLE HOME

NS900

10" LARGE CAPACITY FILTERS



UNIVERSAL
FIT

NSF Certified

- Under NSF/ANSI 42
- Under NSF/ANSI/CAN 372

Universal Fit: Fits most major brands of whole home housings

Grooved: Provides more surface area and greater capacity

Carbon Block: Improves taste and odor of drinking water

Premium Carbon with FACT®

- Low pressure drop allows for high flow rate
- High sediment filter - resistant to clogging

SPECIFICATIONS

Model Number	NS925	NS905	NS917	NSF917
Part Number	7358373	7358365	7358200	7358242
Description	Grooved	Grooved	Carbon Block	Premium Carbon with FACT®
Dimensions	10" x 4.5"	10" x 4.5"	10" x 4.5"	10" x 4.5"
Micron Rating	25	5	25	0.7
Flow Rate (gpm)	20	20	4	22
Max Water Temperature	140°F/60°C	140°F/60°C	100°F/40°C	100°F/40°C
Filter Life	3 Months	3 Months	3 Months	6 Months
Compatible with Systems	NS900	NS900	NS900	NS900

CONTAMINANT REDUCTION

Sediment - Sand, Dirt, Rust	•	•	•	•
Chlorine Taste & Odor			•	•



System tested and certified by
NSF International against NSF/ANSI
Standards 42.

FOR MORE INFORMATION

www.northstarwater.com

ONE YEAR LIMITED WARRANTY ON WHOLE HOME WATER FILTER SYSTEM (except filter cartridges)

Warrantor guarantees, to the original owner, that the Whole Home Water Filter System, when installed and maintained in accordance with the instructions, will be free from defects in materials and workmanship for a period of one (1) year from the date of purchase. If, within the first year, a part proves, after inspection, to be defective, Warrantor will, at its sole option, either replace or repair the part without charge except normal shipping and installation charges. Labor to maintain the equipment is not part of the warranty. Filters, which are expendable, are not covered by the warranty.