

North Star Water Treatment Systems PROFESSIONAL ADVANTAGE COMMERCIAL SERIES WATER SOFTENERS – 2" VALVE

NOTE: All models shipped unassembled. Shipping weights are approximate.

MODEL	RESIN TANK	SHIPPING WEIGHT
PA102S	17" x 58" P/N 7149994	440#
PA102S-1	16" x 65" P/N 7391787	
PA132S	17" x 58" P/N 7149994	500#
PA132S-1	16" x 65" P/N 7391787	

MODEL	RESIN TANK	SHIPPING WEIGHT
PA102D	17" x 58" P/N 7149994	850#
PA102D-1	16" x 65" P/N 7391787	
PA132D	17" x 58" P/N 7149994	960#
PA132D-1	16" x 65" P/N 7391787	

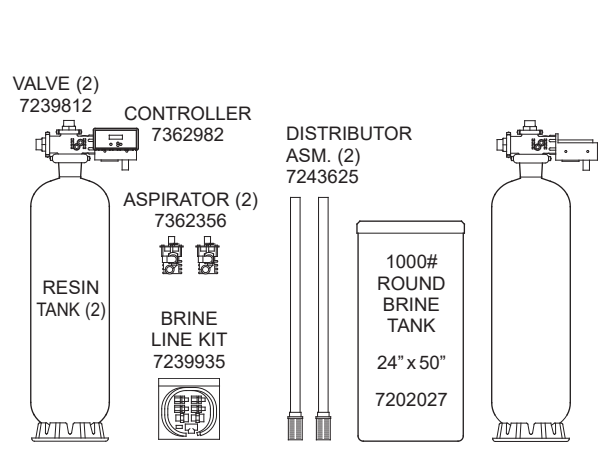
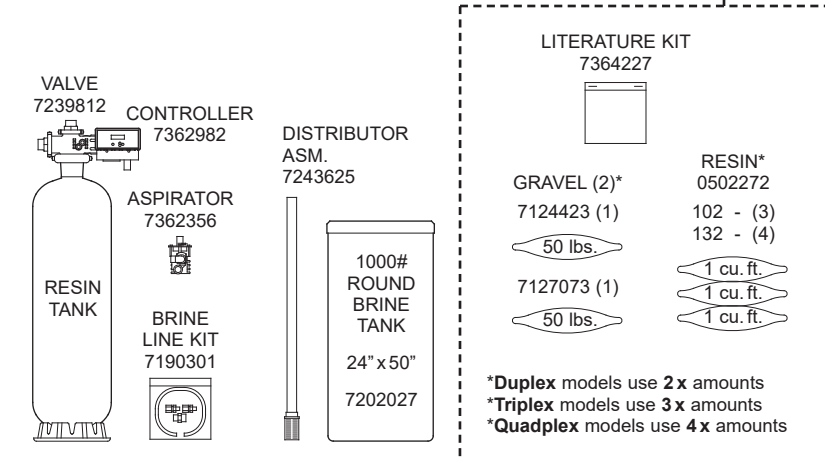

MODEL	RESIN TANK	SHIPPING WEIGHT
PA102T	17" x 58" P/N 7149994	1290#
PA102T-1	16" x 65" P/N 7391787	
PA132T	17" x 58" P/N 7149994	1450#
PA132T-1	16" x 65" P/N 7391787	

MODEL	RESIN TANK	SHIPPING WEIGHT
PA102Q	17" x 58" P/N 7149994	1780#
PA102Q-1	16" x 65" P/N 7391787	
PA132Q	17" x 58" P/N 7149994	1870#
PA132Q-1	16" x 65" P/N 7391787	

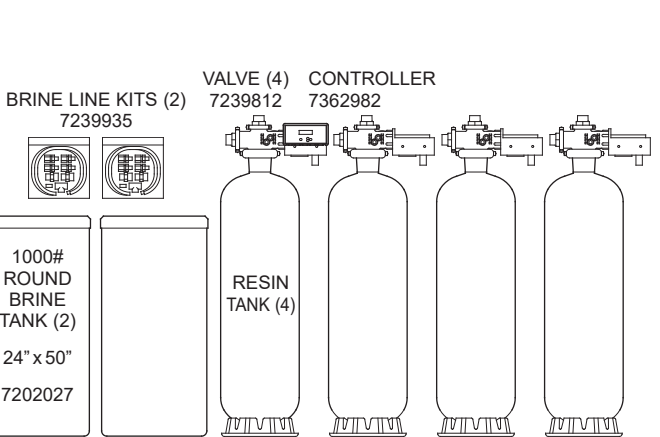
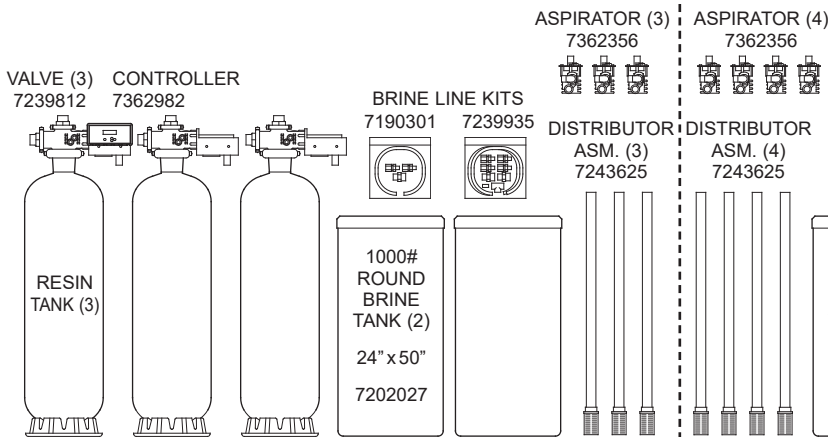

North Star Water Treatment Systems **PROFESSIONAL ADVANTAGE** COMMERCIAL SERIES WATER SOFTENERS – 2" VALVE

NOTE: All models shipped unassembled. Shipping weights are approximate.

MODEL	RESIN TANK	SHIPPING WEIGHT
PA162S	17" x 72" P/N 7153561	600#
PA162S-1	18" x 65" P/N 7391795	

MODEL	RESIN TANK	SHIPPING WEIGHT
PA162D	17" x 72" P/N 7153561	1090#
PA162D-1	18" x 65" P/N 7391795	

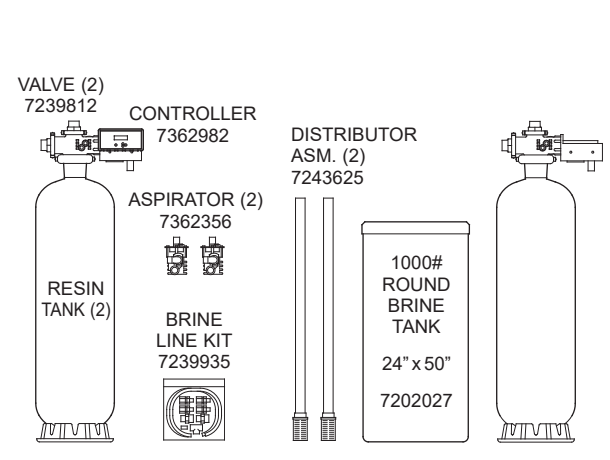
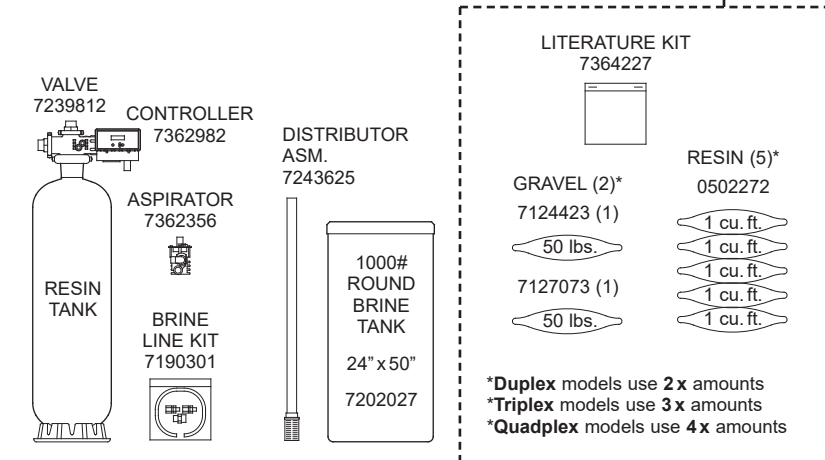

MODEL	RESIN TANK	SHIPPING WEIGHT
PA162T	17" x 72" P/N 7153561	1640#
PA162T-1	18" x 65" P/N 7391795	

MODEL	RESIN TANK	SHIPPING WEIGHT
PA162Q	17" x 72" P/N 7153561	2130#
PA162Q-1	18" x 65" P/N 7391795	

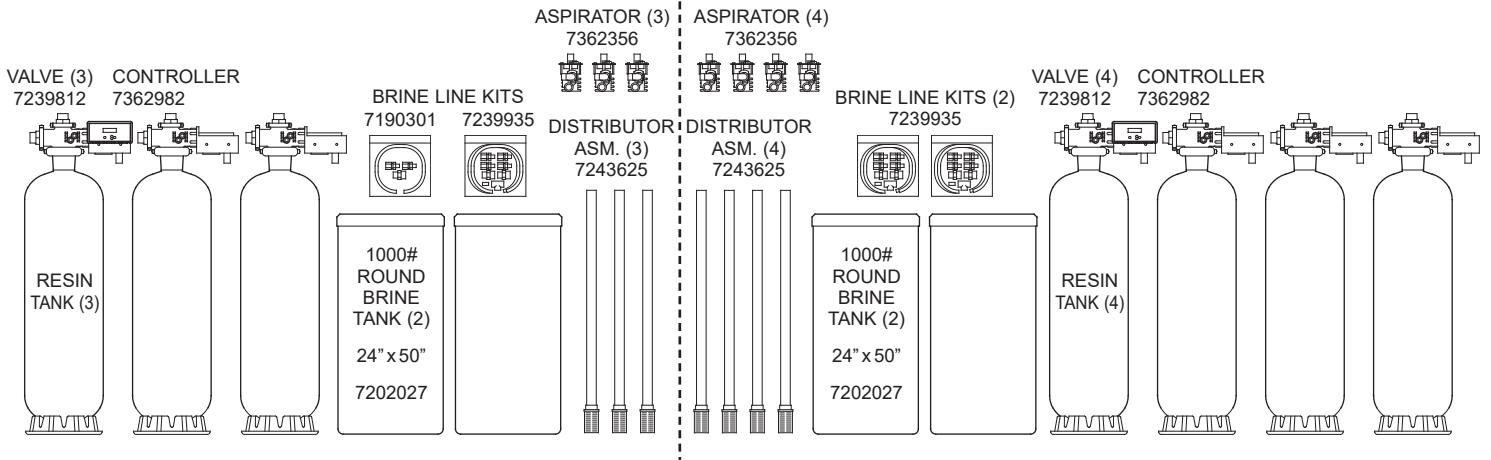

North Star Water Treatment Systems PROFESSIONAL ADVANTAGE COMMERCIAL SERIES WATER SOFTENERS – 2" VALVE

NOTE: All models shipped unassembled. Shipping weights are approximate.

MODEL	RESIN TANK	SHIPPING WEIGHT
PA192S	24" x 72" P/N 7298777	820#
PA192S-1	24" x 72" P/N 7391800	
PA252S	24" x 72" P/N 7298777	920#
PA252S-1	24" x 72" P/N 7391800	
PA322S	24" x 72" P/N 7298777	1030#
PA322S-1	24" x 72" P/N 7391800	

MODEL	RESIN TANK	SHIPPING WEIGHT
PA192D	24" x 72" P/N 7298777	1490#
PA192D-1	24" x 72" P/N 7391800	
PA252D	24" x 72" P/N 7298777	1710#
PA252D-1	24" x 72" P/N 7391800	
PA322D	24" x 72" P/N 7298777	1920#
PA322D-1	24" x 72" P/N 7391800	

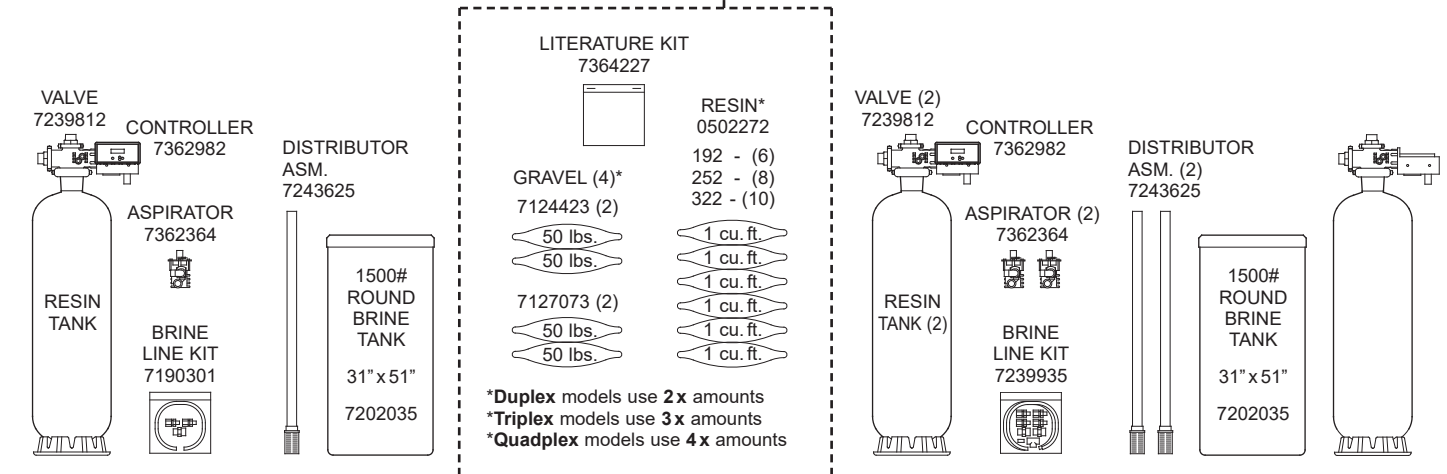

MODEL	RESIN TANK	SHIPPING WEIGHT
PA192T	24" x 72" P/N 7298777	2260#
PA192T-1	24" x 72" P/N 7391800	
PA252T	24" x 72" P/N 7298777	2590#
PA252T-1	24" x 72" P/N 7391800	
PA322T	24" x 72" P/N 7298777	2910#
PA322T-1	24" x 72" P/N 7391800	

MODEL	RESIN TANK	SHIPPING WEIGHT
PA192Q	24" x 72" P/N 7298777	2940#
PA192Q-1	24" x 72" P/N 7391800	
PA252Q	24" x 72" P/N 7298777	3410#
PA252Q-1	24" x 72" P/N 7391800	
PA322Q	24" x 72" P/N 7298777	3840#
PA322Q-1	24" x 72" P/N 7391800	

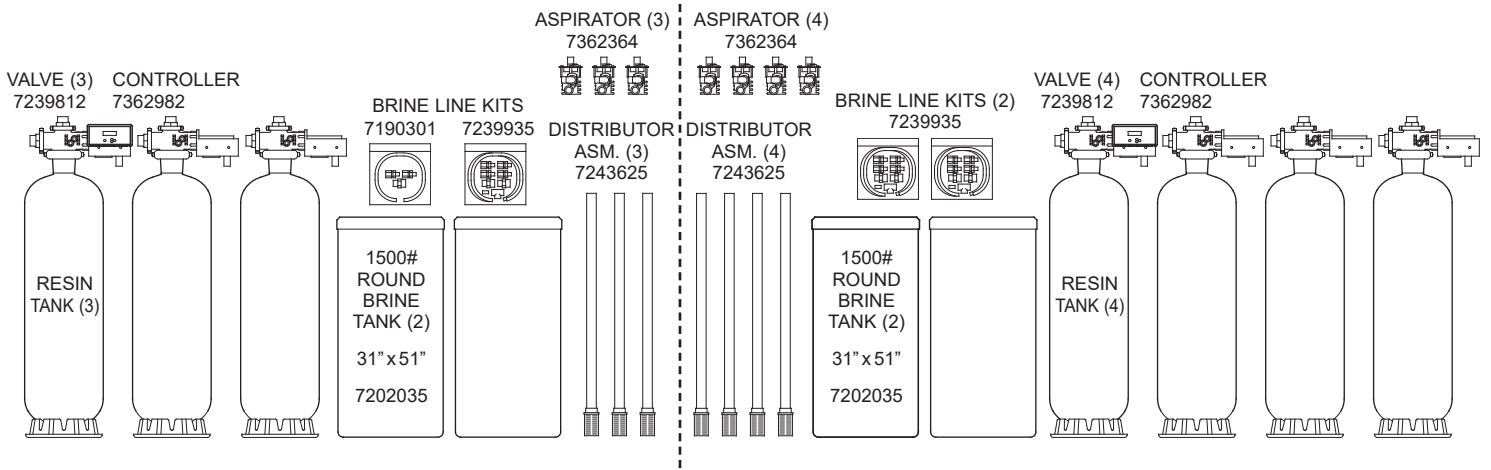

North Star Water Treatment Systems **PROFESSIONAL ADVANTAGE** COMMERCIAL SERIES WATER SOFTENERS – 2" VALVE

NOTE: All models shipped unassembled. Shipping weights are approximate.

ADAPTOR 7345516
VALVE 7239812
CONTROLLER 7362982
ASPIRATOR 7362372
BRINE LINE KIT 7190301

PA362S - 1310#
PA452S - 1470#

DISTRIBUTOR ASM. 7243625

2500# ROUND BRINE TANK 41" x 51" 940027

RESIN TANK 30" x 72" 0403007

LITERATURE KIT 7364227

GRAVEL (6)*
7124423 (3)
1 cu. ft.
1 cu. ft.
1 cu. ft.
7127073 (3)
1 cu. ft.
1 cu. ft.
1 cu. ft.

RESIN* 0502272
362 - (12)
452 - (15)

*Duplex models use 2x amounts
*Triplex models use 3x amounts
*Quadplex models use 4x amounts

ADAPTOR (2) 7345516
VALVE (2) 7239812
CONTROLLER 7362982
ASPIRATOR (2) 7362372
BRINE LINE KIT 7239935

PA362D - 2480#
PA452D - 2840#

DISTRIBUTOR ASM. (2) 7243625

2500# ROUND BRINE TANK 41" x 51" 940027

RESIN TANK (2) 30" x 72" 0403007

ADAPTOR (3) 7345516
VALVE (3) 7239812
CONTROLLER 7362982

PA362T - 3740#
PA452T - 4270#

BRINE LINE KITS 7190301 7239935

DISTRIBUTOR ASM. (3) 7243625

2500# ROUND BRINE TANK (2) 41" x 51" 940027

RESIN TANK (3) 30" x 72" 0403007

ASPIRATOR (3) 7362372
ASPIRATOR (4) 7362372

DISTRIBUTOR ASM. (4) 7243625

ADAPTOR (4) 7345516
VALVE (4) 7239812
CONTROLLER 7362982

PA362Q - 4950#
PA452Q - 5640#

BRINE LINE KITS (2) 7239935

DISTRIBUTOR ASM. (4) 7243625

2500# ROUND BRINE TANK (2) 41" x 51" 940027

RESIN TANK (4) 30" x 72" 0403007

North Star Water Treatment Systems **PROFESSIONAL ADVANTAGE** COMMERCIAL SERIES WATER SOFTENERS – 2" VALVE

NOTE: All models shipped unassembled. Shipping weights are approximate.

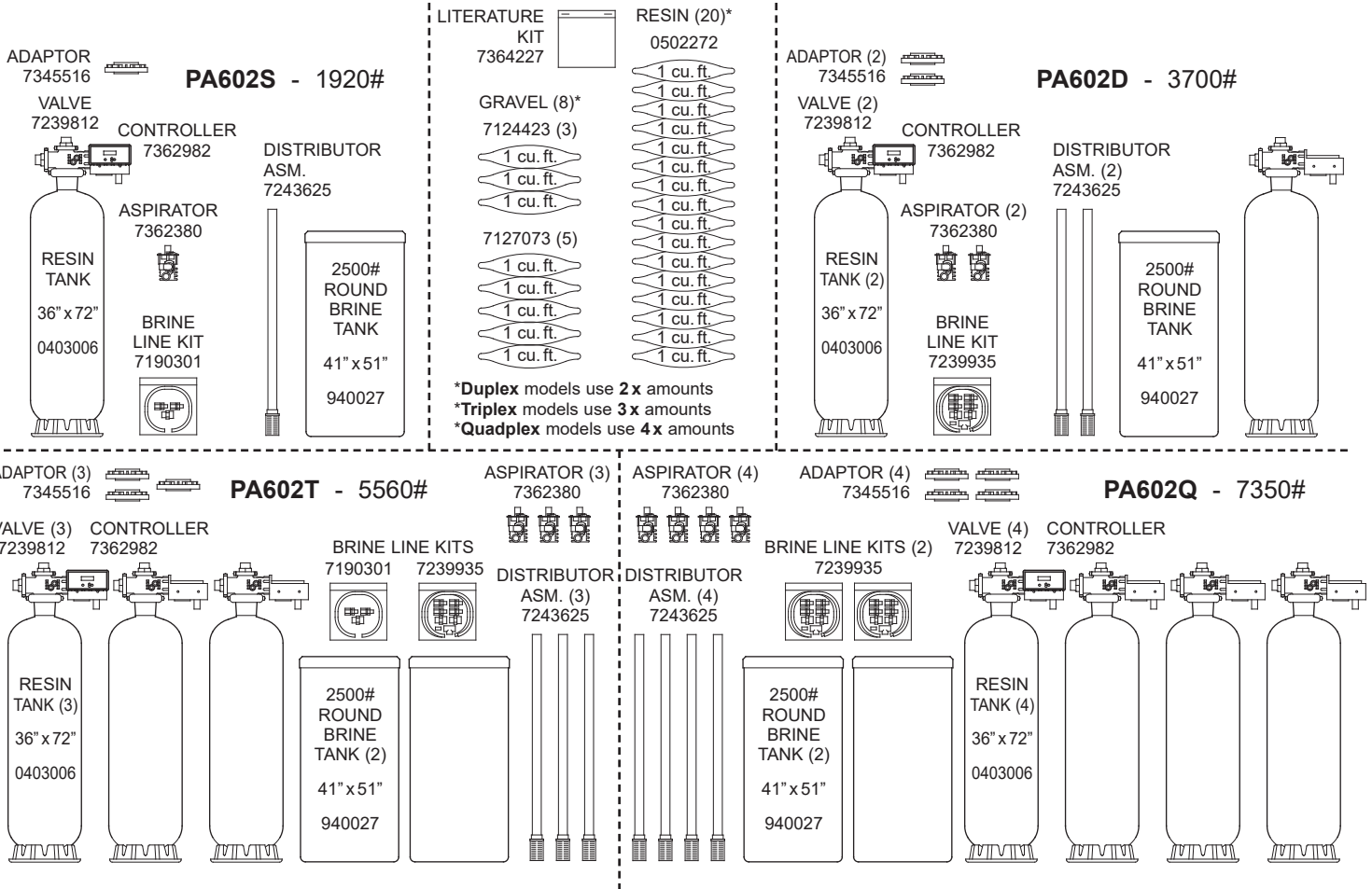

North Star Water Treatment Systems PROFESSIONAL ADVANTAGE COMMERCIAL SERIES WATER FILTERS – 2" VALVE

NOTE: All models shipped unassembled. Shipping weights are approximate.

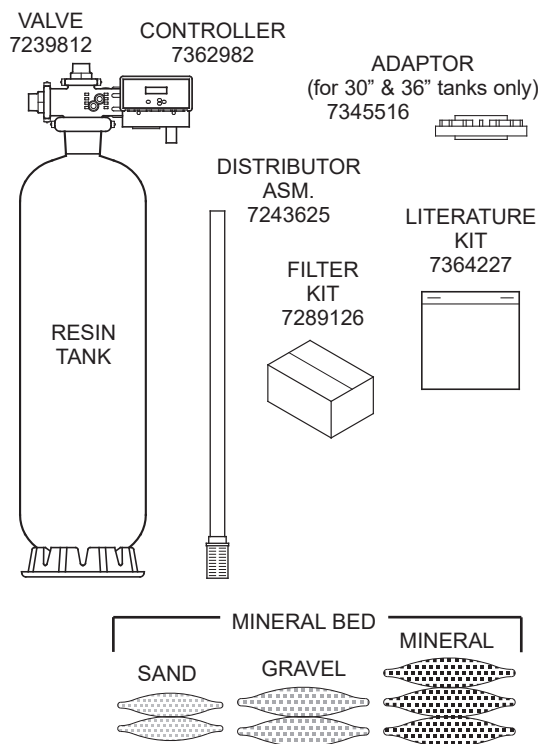

MODEL	RESIN TANK	SHIPPING WEIGHT	MINERAL BED
PA172XS	17" x 58" P/N 7149994	252#	see table below
PA172XS-1	16" x 65" P/N 7391787		
PA242XS	24" x 72" P/N 7298777	358#	
PA242XS-1	24" x 72" P/N 7391800		
PA302XS	30" x 72" P/N 0403007	765#	
PA362XS	36" x 72" P/N 0403006	930#	
PA172CS	17" x 58" P/N 7149994	420#	
PA172CS-1	16" x 65" P/N 7391787		
PA242CS	24" x 72" P/N 7298777	770#	
PA242CS-1	24" x 72" P/N 7391800		
PA302CS	30" x 72" P/N 0403007	1185#	
PA362CS	36" x 72" P/N 0403006	1490#	
PA172MS	17" x 58" P/N 7149994	560#	
PA172MS-1	16" x 65" P/N 7391787		
PA242MS	24" x 72" P/N 7298777	1060#	
PA242MS-1	24" x 72" P/N 7391800		
PA302MS	30" x 72" P/N 0403007	1620#	
PA172GS	17" x 58" P/N 7149994	660#	
PA172GS-1	16" x 65" P/N 7391787		
PA242GS	24" x 72" P/N 7298777	1160#	
PA242GS-1	24" x 72" P/N 7391800		
PA302GS	30" x 72" P/N 0403007	1780#	

MODEL	GRAVEL 7124423		FILTER SAND 0993080		ACTIVATED CARBON 7336834	GREENSAND PLUS™ 7331101	ANTHRACITE 0993070		GARNET 0993090	
	lbs.	bags	lbs.	bags	1 cu. ft. bags	1/2 cu. ft. bags	lbs.	bags	lbs.	bags
PA172XS, PA172XS-1	100	2	-	-	-	-	-	-	-	-
PA242XS, PA242XS-1	150	3	-	-	-	-	-	-	-	-
PA302XS	250	5	-	-	-	-	-	-	-	-
PA362XS	300	6	-	-	-	-	-	-	-	-
PA172CS, PA172CS-1	100	2	-	-	4	-	-	-	-	-
PA242CS, PA242CS-1	150	3	-	-	10	-	-	-	-	-
PA302CS	250	5	-	-	15	-	-	-	-	-
PA362CS	300	6	-	-	20	-	-	-	-	-
PA172MS, PA172MS-1	100	2	100	2	-	-	156	3	50	1
PA242MS, PA242MS-1	150	3	250	5	-	-	312	6	150	3
PA302MS	250	5	350	7	-	-	520	10	200	4
PA172GS, PA172GS-1	100	2	-	-	-	6	78*	2*	50	1
PA242GS, PA242GS-1	150	3	-	-	-	12	156	3	150	3
PA302GS	250	5	-	-	-	18	260	5	200	4

Greensand Plus™ is a trademark of Inversand Company.

*1-1/2 of the 2 bags included are used.

North Star Water Treatment Systems **PROFESSIONAL ADVANTAGE** COMMERCIAL SERIES WATER FILTERS – 2" VALVE

NOTE: All models shipped unassembled. Shipping weights are approximate.

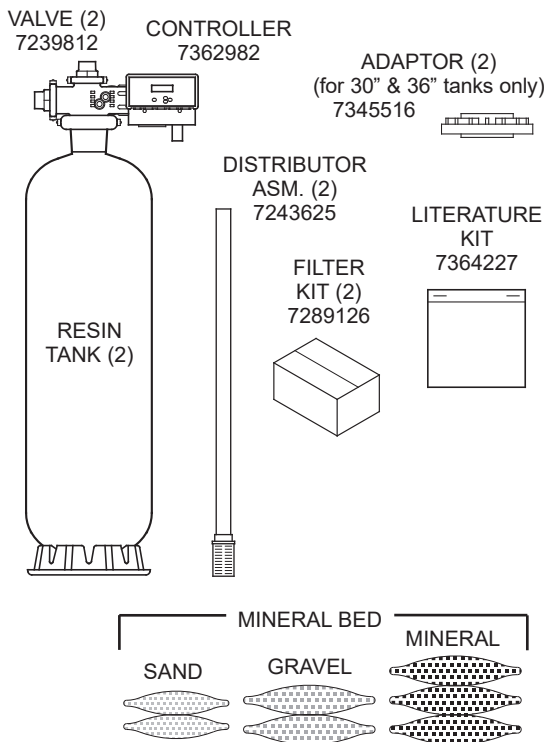

MODEL	RESIN TANK	SHIPPING WEIGHT	MINERAL BED
PA172XD	17" x 58" P/N 7149994	494#	see table below
PA172XD-1	16" x 65" P/N 7391787		
PA242XD	24" x 72" P/N 7298777	680#	
PA242XD-1	24" x 72" P/N 7391800		
PA302XD	30" x 72" P/N 0403007	1480#	
PA362XD	36" x 72" P/N 0403006	1810#	
PA172CD	17" x 58" P/N 7149994	830#	
PA172CD-1	16" x 65" P/N 7391787		
PA242CD	24" x 72" P/N 7298777	1570#	
PA242CD-1	24" x 72" P/N 7391800		
PA302CD	30" x 72" P/N 0403007	2320#	
PA362CD	36" x 72" P/N 0403006	2930#	
PA172MD	17" x 58" P/N 7149994	1110#	
PA172MD-1	16" x 65" P/N 7391787		
PA242MD	24" x 72" P/N 7298777	2110#	
PA242MD-1	24" x 72" P/N 7391800		
PA302MD	30" x 72" P/N 0403007	3200#	
PA172GD	17" x 58" P/N 7149994	1260#	
PA172GD-1	16" x 65" P/N 7391787		
PA242GD	24" x 72" P/N 7298777	2320#	
PA242GD-1	24" x 72" P/N 7391800		
PA302GD	30" x 72" P/N 0403007	3510#	

MODEL	GRAVEL 7124423		FILTER SAND 0993080		ACTIVATED CARBON 7336834	GREENSAND PLUS™ 7331101	ANTHRACITE 0993070		GARNET 0993090	
	lbs.	bags	lbs.	bags	1 cu. ft. bags	1/2 cu. ft. bags	lbs.	bags	lbs.	bags
PA172XD, PA172XD-1	200	4	–	–	–	–	–	–	–	–
PA242XD, PA242XD-1	300	6	–	–	–	–	–	–	–	–
PA302XD	500	10	–	–	–	–	–	–	–	–
PA362XD	600	12	–	–	–	–	–	–	–	–
PA172CD, PA172CD-1	200	4	–	–	8	–	–	–	–	–
PA242CD, PA242CD-1	300	6	–	–	20	–	–	–	–	–
PA302CD	500	10	–	–	30	–	–	–	–	–
PA362CD	600	12	–	–	40	–	–	–	–	–
PA172MD, PA172MD-1	200	4	200	4	–	–	312	6	100	2
PA242MD, PA242MD-1	300	6	500	10	–	–	624	12	300	6
PA302MD	500	10	700	14	–	–	1040	20	400	8
PA172GD, PA172GD-1	200	4	–	–	–	12	156	3	100	2
PA242GD, PA242GD-1	300	6	–	–	–	24	312	6	300	6
PA302GD	500	10	–	–	–	36	520	10	400	8

Greensand Plus™ is a trademark of Inversand Company.

North Star Water Treatment Systems **PROFESSIONAL ADVANTAGE** COMMERCIAL SERIES WATER FILTERS – 2" VALVE

NOTE: All models shipped unassembled. Shipping weights are approximate.

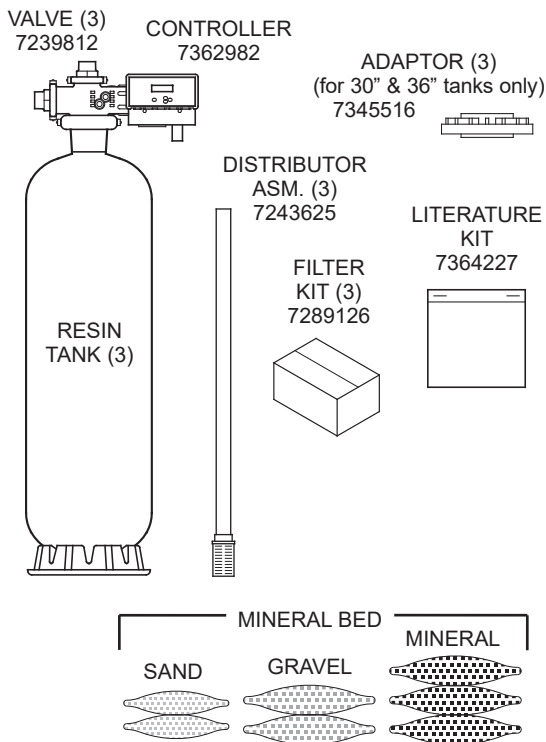

MODEL	RESIN TANK	SHIPPING WEIGHT	MINERAL BED
PA172XT	17" x 58" P/N 7149994	746#	see table below
PA172XT-1	16" x 65" P/N 7391787		
PA242XT	24" x 72" P/N 7298777	1060#	
PA242XT-1	24" x 72" P/N 7391800		
PA302XT	30" x 72" P/N 0403007	2240#	
PA362XT	36" x 72" P/N 0403006	2770#	
PA172CT	17" x 58" P/N 7149994	1250#	
PA172CT-1	16" x 65" P/N 7391787		
PA242CT	24" x 72" P/N 7298777	2320#	
PA242CT-1	24" x 72" P/N 7391800		
PA302CT	30" x 72" P/N 0403007	3500#	
PA362CT	36" x 72" P/N 0403006	4410#	
PA172MT	17" x 58" P/N 7149994	1660#	
PA172MT-1	16" x 65" P/N 7391787		
PA242MT	24" x 72" P/N 7298777	3200#	
PA242MT-1	24" x 72" P/N 7391800		
PA302MT	30" x 72" P/N 0403007	4823#	
PA172GT	17" x 58" P/N 7149994	1920#	
PA172GT-1	16" x 65" P/N 7391787		
PA242GT	24" x 72" P/N 7298777	3480#	
PA242GT-1	24" x 72" P/N 7391800		
PA302GT	30" x 72" P/N 0403007	5340#	

MODEL	GRAVEL 7124423		FILTER SAND 0993080		ACTIVATED CARBON 7336834	GREENSAND PLUS™ 7331101	ANTHRACITE 0993070		GARNET 0993090	
	lbs.	bags	lbs.	bags	1 cu. ft. bags	1/2 cu. ft. bags	lbs.	bags	lbs.	bags
PA172XT, PA172XT-1	300	6	–	–	–	–	–	–	–	–
PA242XT, PA242XT-1	450	9	–	–	–	–	–	–	–	–
PA302XT	750	15	–	–	–	–	–	–	–	–
PA362XT	900	18	–	–	–	–	–	–	–	–
PA172CT, PA172CT-1	300	6	–	–	12	–	–	–	–	–
PA242CT, PA242CT-1	450	9	–	–	30	–	–	–	–	–
PA302CT	750	15	–	–	45	–	–	–	–	–
PA362CT	900	18	–	–	60	–	–	–	–	–
PA172MT, PA172MT-1	300	6	300	6	–	–	468	9	150	3
PA242MT, PA242MT-1	450	9	750	15	–	–	936	18	450	9
PA302MT	750	15	1050	21	–	–	1560	30	600	12
PA172GT, PA172GT-1	300	6	–	–	–	18	234*	5*	150	3
PA242GT, PA242GT-1	450	9	–	–	–	36	468	9	450	9
PA302GT	750	15	–	–	–	54	780	15	600	12

Greensand Plus™ is a trademark of Inversand Company.

*4-1/2 of the 5 bags included are used.

North Star Water Treatment Systems PROFESSIONAL ADVANTAGE COMMERCIAL SERIES WATER FILTERS – 2" VALVE

NOTE: All models shipped unassembled. Shipping weights are approximate.

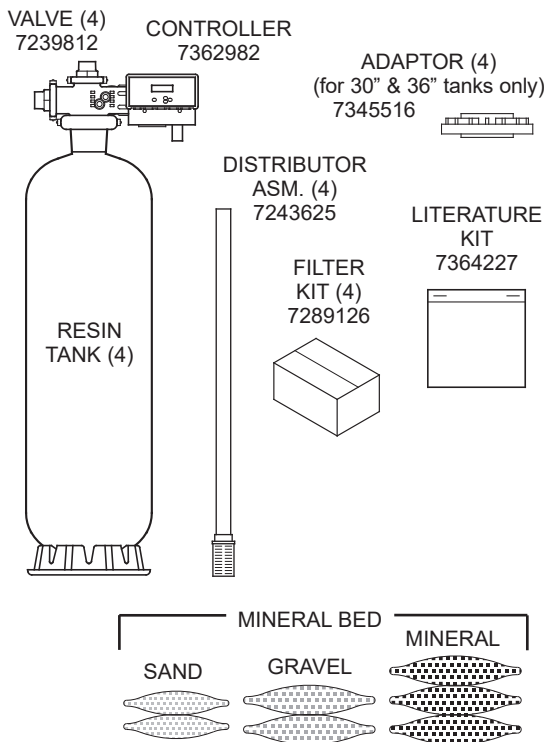

MODEL	RESIN TANK	SHIPPING WEIGHT	MINERAL BED
PA172XQ	17" x 58" P/N 7149994	988#	see table below
PA172XQ-1	16" x 65" P/N 7391787		
PA242XQ	24" x 72" P/N 7298777	1370#	
PA242XQ-1	24" x 72" P/N 7391800		
PA302XQ	30" x 72" P/N 0403007	3060#	
PA362XQ	36" x 72" P/N 0403006	3700#	
PA172CQ	17" x 58" P/N 7149994	2080#	
PA172CQ-1	16" x 65" P/N 7391787		
PA242CQ	24" x 72" P/N 7298777	3050#	
PA242CQ-1	24" x 72" P/N 7391800		
PA302CQ	30" x 72" P/N 0403007	4740#	
PA362CQ	36" x 72" P/N 0403006	5940#	
PA172MQ	17" x 58" P/N 7149994	2210#	
PA172MQ-1	16" x 65" P/N 7391787		
PA242MQ	24" x 72" P/N 7298777	4250#	
PA242MQ-1	24" x 72" P/N 7391800		
PA302MQ	30" x 72" P/N 0403007	6360#	
PA172GQ	17" x 58" P/N 7149994	2520#	
PA172GQ-1	16" x 65" P/N 7391787		
PA242GQ	24" x 72" P/N 7298777	4670#	
PA242GQ-1	24" x 72" P/N 7391800		
PA302GQ	30" x 72" P/N 0403007	6980#	

MODEL	GRAVEL 7124423		FILTER SAND 0993080		ACTIVATED CARBON 7336834	GREENSAND PLUS™ 7331101	ANTHRACITE 0993070		GARNET 0993090	
	lbs.	bags	lbs.	bags	1 cu. ft. bags	1/2 cu. ft. bags	lbs.	bags	lbs.	bags
PA172XQ, PA172XQ-1	400	8	-	-	-	-	-	-	-	-
PA242XQ, PA242XQ-1	600	12	-	-	-	-	-	-	-	-
PA302XQ	1000	20	-	-	-	-	-	-	-	-
PA362XQ	1200	24	-	-	-	-	-	-	-	-
PA172CQ, PA172CQ-1	400	8	-	-	16	-	-	-	-	-
PA242CQ, PA242CQ-1	600	12	-	-	40	-	-	-	-	-
PA302CQ	1000	20	-	-	60	-	-	-	-	-
PA362CQ	1200	24	-	-	80	-	-	-	-	-
PA172MQ, PA172MQ-1	400	8	400	8	-	-	624	12	200	4
PA242MQ, PA242MQ-1	600	12	1000	20	-	-	1248	24	600	12
PA302MQ	1000	20	1400	28	-	-	2080	40	800	16
PA172GQ, PA172GQ-1	400	8	-	-	-	24	312	6	200	4
PA242GQ, PA242GQ-1	600	12	-	-	-	48	624	12	600	12
PA302GQ	1000	20	-	-	-	72	1040	20	800	16

Greensand Plus™ is a trademark of Inversand Company.

North Star Water Treatment Systems PROFESSIONAL ADVANTAGE COMMERCIAL SERIES WATER FILTERS – 2” VALVE

BEDDING SEQUENCE OF GRAVEL & MINERALS

NOTE: Be sure distributor assembly is centered in tank before filling.

**NO MEDIA
(GRAVEL ONLY) FILTERS**

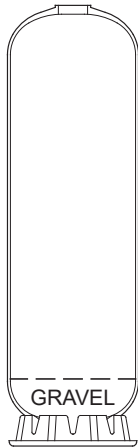

CARBON FILTERS

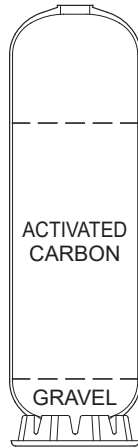

MULTI-MEDIA FILTERS



**GREENSAND PLUS™
FILTERS**



North Star Water Treatment Systems PROFESSIONAL ADVANTAGE COMMERCIAL SERIES – 2” VALVE

Media		
	Part Number	Weight (lbs.)
Resin	0502272	53
Gravel, Quartz	7124415	17
	7124423	50
Gravel, Medium	7127073	50
Anthracite	0993070	52
Garnet	0993090	50
Sand, Filter	0993080	50
Carbon, Activated	7336834	27.5
Greensand Plus™	7331101	44

Accessories	
	Part Number
External No Hard Water Shutoff Kit, 2” Valve, DC	7362225
Piston Plug, 2” Valve	7207750
Grip Ring for Above	7192769

Greensand Plus™ is a trademark of Inversand Company.