

North Star Water Treatment Systems **PROFESSIONAL ADVANTAGE** COMMERCIAL SERIES WATER SOFTENERS – 2" VALVE

NOTE: All models shipped unassembled. Shipping weights are approximate.

<p>PA102S - 440# PA132S - 500#</p>	<p>LITERATURE KIT 7364227</p> <p>GRAVEL (2)* 7124423 (1) 50 lbs. 7127073 (1) 50 lbs.</p> <p>RESIN* 0502272 102 - (3) 1 cu. ft. 132 - (4) 1 cu. ft.</p> <p>*Duplex models use 2x amounts *Triplex models use 3x amounts *Quadplex models use 4x amounts</p>	<p>PA102D - 850# PA132D - 960#</p>
<p>PA102T - 1290# PA132T - 1450#</p>	<p>ASPIRATOR (3) 7362356</p> <p>ASPIRATOR (4) 7362356</p> <p>BRINE LINE KITS (2) 7239935</p> <p>DISTRIBUTOR ASM. (3) 7243625</p> <p>DISTRIBUTOR ASM. (4) 7243625</p>	<p>PA102Q - 1700# PA132Q - 1870#</p>
<p>PA162S - 600#</p>	<p>LITERATURE KIT 7364227</p> <p>GRAVEL (2)* 7124423 (1) 50 lbs. 7127073 (1) 50 lbs.</p> <p>RESIN (5)* 0502272 1 cu. ft. 1 cu. ft. 1 cu. ft. 1 cu. ft.</p> <p>*Duplex models use 2x amounts *Triplex models use 3x amounts *Quadplex models use 4x amounts</p>	<p>PA162D - 1090#</p>
<p>PA162T - 1640#</p>	<p>ASPIRATOR (3) 7362356</p> <p>ASPIRATOR (4) 7362356</p> <p>BRINE LINE KITS (2) 7239935</p> <p>DISTRIBUTOR ASM. (3) 7243625</p> <p>DISTRIBUTOR ASM. (4) 7243625</p>	<p>PA162Q - 2130#</p>

North Star Water Treatment Systems **PROFESSIONAL ADVANTAGE** COMMERCIAL SERIES WATER SOFTENERS – 2" VALVE

NOTE: All models shipped unassembled. Shipping weights are approximate.

<p>PA192S - 820# PA252S - 920# PA322S - 1030#</p> <p>VALVE 7239812 CONTROLLER 7362982 DISTRIBUTOR ASM. 7243625 ASPIRATOR 7362364 RESIN TANK 24" x 72" 7298777 BRINE LINE KIT 7190301 1500# ROUND BRINE TANK 31" x 51" 7202035</p>	<p>LITERATURE KIT 7364227</p> <p>RESIN* 0502272 192 - (6) 252 - (8) 322 - (10)</p> <p>GRAVEL (4)* 7124423 (2) 50 lbs. 1 cu. ft. 50 lbs. 1 cu. ft. 7127073 (2) 50 lbs. 1 cu. ft. 50 lbs. 1 cu. ft.</p> <p>*Duplex models use 2x amounts *Triplex models use 3x amounts *Quadplex models use 4x amounts</p>	<p>PA192D - 1490# PA252D - 1710# PA322D - 1920#</p> <p>VALVE (2) 7239812 CONTROLLER 7362982 DISTRIBUTOR ASM. (2) 7243625 ASPIRATOR (2) 7362364 RESIN TANK (2) 24" x 72" 7298777 BRINE LINE KIT 7239935 1500# ROUND BRINE TANK 31" x 51" 7202035</p>
<p>PA192T - 2260# PA252T - 2590# PA322T - 2910#</p> <p>VALVE (3) 7239812 CONTROLLER 7362982 DISTRIBUTOR ASM. (3) 7243625 ASPIRATOR (3) 7362364 RESIN TANK (3) 24" x 72" 7298777 BRINE LINE KITS 7190301 7239935 1500# ROUND BRINE TANK (2) 31" x 51" 7202035</p>	<p>ASPIRATOR (4) 7362364 DISTRIBUTOR ASM. (4) 7243625</p>	<p>PA192Q - 2940# PA252Q - 3410# PA322Q - 3840#</p> <p>VALVE (4) 7239812 CONTROLLER 7362982 DISTRIBUTOR ASM. (4) 7243625 ASPIRATOR (4) 7362364 RESIN TANK (4) 24" x 72" 7298777 BRINE LINE KITS (2) 7239935 1500# ROUND BRINE TANK (2) 31" x 51" 7202035</p>
<p>PA362S - 1310# PA452S - 1470#</p> <p>ADAPTOR 7345516 VALVE 7239812 CONTROLLER 7362982 DISTRIBUTOR ASM. 7243625 ASPIRATOR 7362372 RESIN TANK 30" x 72" 403007 BRINE LINE KIT 7190301 2500# ROUND BRINE TANK 41" x 51" 940027</p>	<p>LITERATURE KIT 7364227</p> <p>RESIN* 0502272 362 - (12) 452 - (15)</p> <p>GRAVEL (6)* 7124423 (3) 1 cu. ft. 1 cu. ft. 1 cu. ft. 7127073 (3) 1 cu. ft. 1 cu. ft. 1 cu. ft.</p> <p>*Duplex models use 2x amounts *Triplex models use 3x amounts *Quadplex models use 4x amounts</p>	<p>PA362D - 2480# PA452D - 2840#</p> <p>ADAPTOR (2) 7345516 VALVE (2) 7239812 CONTROLLER 7362982 DISTRIBUTOR ASM. (2) 7243625 ASPIRATOR (2) 7362372 RESIN TANK (2) 30" x 72" 403007 BRINE LINE KIT 7239935 2500# ROUND BRINE TANK 41" x 51" 940027</p>
<p>PA362T - 3740# PA452T - 4270#</p> <p>ADAPTOR (3) 7345516 VALVE (3) 7239812 CONTROLLER 7362982 DISTRIBUTOR ASM. (3) 7243625 ASPIRATOR (3) 7362372 RESIN TANK (3) 30" x 72" 403007 BRINE LINE KITS 7190301 7239935 2500# ROUND BRINE TANK (2) 41" x 51" 940027</p>	<p>ASPIRATOR (4) 7362372 DISTRIBUTOR ASM. (4) 7243625</p>	<p>PA362Q - 4950# PA452Q - 5640#</p> <p>ADAPTOR (4) 7345516 VALVE (4) 7239812 CONTROLLER 7362982 DISTRIBUTOR ASM. (4) 7243625 ASPIRATOR (4) 7362372 RESIN TANK (4) 30" x 72" 403007 BRINE LINE KITS (2) 7239935 2500# ROUND BRINE TANK (2) 41" x 51" 940027</p>

North Star Water Treatment Systems **PROFESSIONAL ADVANTAGE** COMMERCIAL SERIES WATER SOFTENERS – 2" VALVE

NOTE: All models shipped unassembled. Shipping weights are approximate.

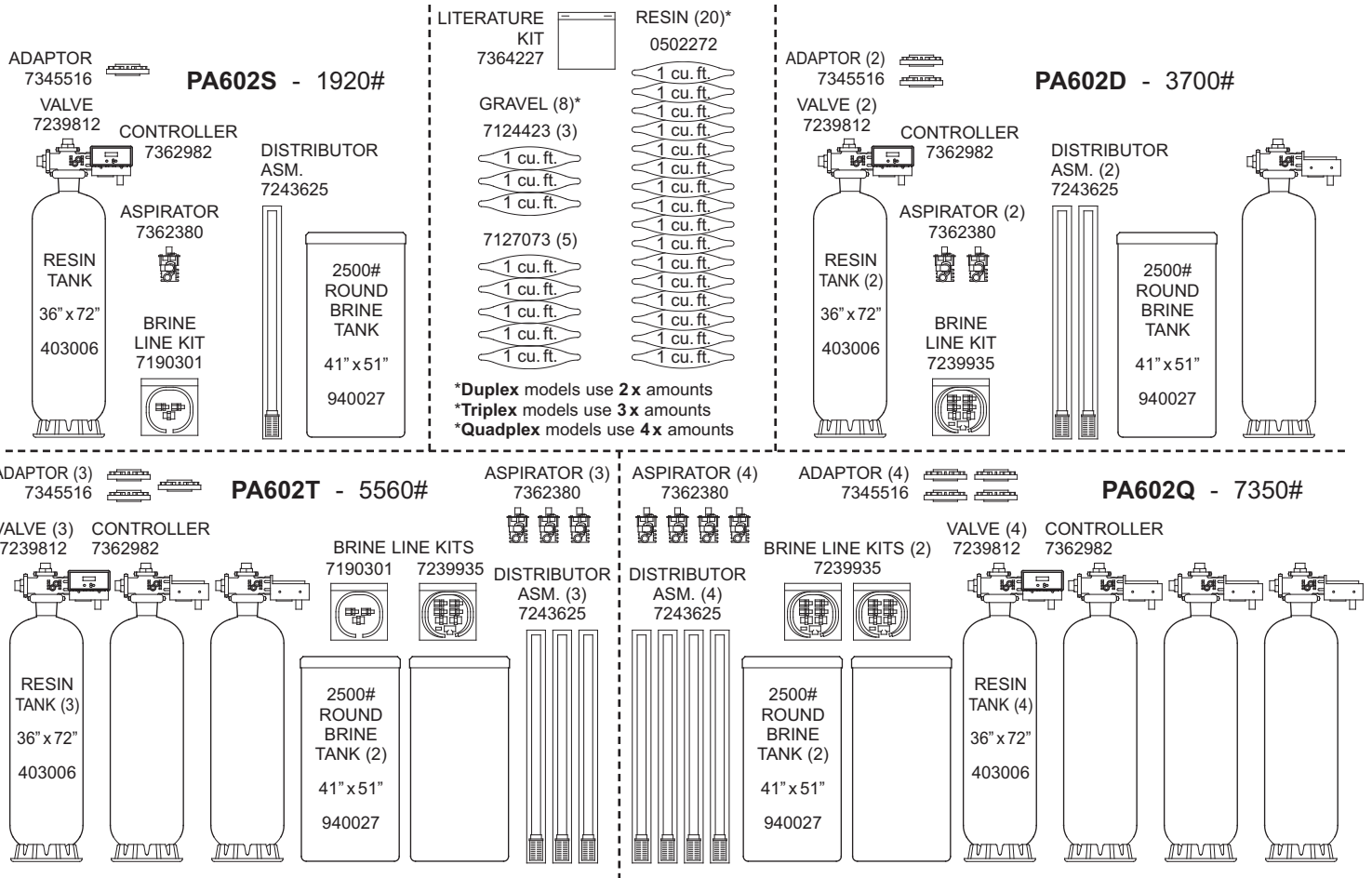

North Star Water Treatment Systems PROFESSIONAL ADVANTAGE COMMERCIAL SERIES WATER FILTERS – 2" VALVE

NOTE: All models shipped unassembled. Shipping weights are approximate.

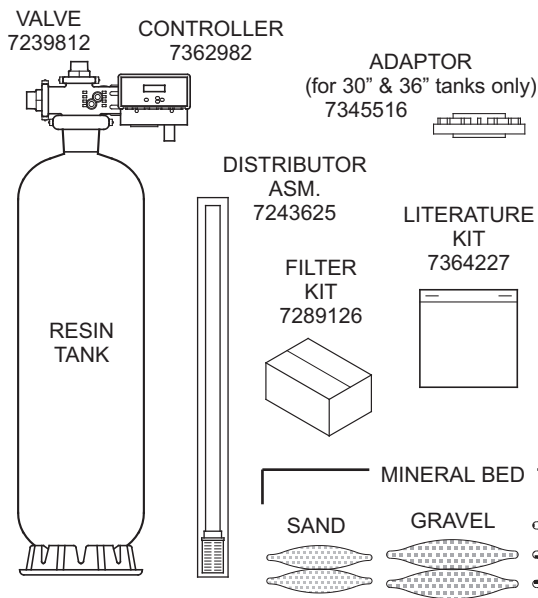

MODEL	SHIPPING WEIGHT	RESIN TANK	MINERAL BED
PA172XS	252#	17" x 58" P/N 7149994	see table below
PA242XS	358#	24" x 72" P/N 7298777	
PA172CS	420#	17" x 58" P/N 7149994	
PA242CS	770#	24" x 72" P/N 7298777	
PA302CS	1185#	30" x 72" P/N 0403007	
PA362CS	1490#	36" x 72" P/N 0403006	
PA172MS	560#	17" x 58" P/N 7149994	
PA242MS	1060#	24" x 72" P/N 7298777	
PA302MS	1620#	30" x 72" P/N 0403007	
PA172GS	660#	17" x 58" P/N 7149994	
PA242GS	1160#	24" x 72" P/N 7298777	
PA302GS	1780#	30" x 72" P/N 0403007	

MODEL	GRAVEL 7124423		FILTER SAND 0993080		ACTIVATED CARBON 3424509	GREENSAND PLUS™ 7331101	ANTHRACITE 0993070		GARNET 0993090	
	lbs.	bags	lbs.	bags	1 cu. ft. bags	1/2 cu. ft. bags	lbs.	bags	lbs.	bags
PA172XS	100	2	-	-	-	-	-	-	-	-
PA242XS	150	3	-	-	-	-	-	-	-	-
PA172CS	100	2	-	-	4	-	-	-	-	-
PA242CS	150	3	-	-	10	-	-	-	-	-
PA302CS	250	5	-	-	15	-	-	-	-	-
PA362CS	300	6	-	-	20	-	-	-	-	-
PA172MS	100	2	100	2	-	-	156	3	50	1
PA242MS	150	3	250	5	-	-	312	6	150	3
PA302MS	250	5	350	7	-	-	520	10	200	4
PA172GS	100	2	-	-	-	6	78*	2*	50	1
PA242GS	150	3	-	-	-	12	156	3	150	3
PA302GS	250	5	-	-	-	18	260	5	200	4

Greensand Plus™ is a trademark of Inversand Company.

*1-1/2 of the 2 bags included are used.

BEDDING SEQUENCE OF GRAVEL & MINERALS

NOTE: Be sure distributor assembly is centered in tank before filling.

NO MEDIA (GRAVEL ONLY) FILTERS

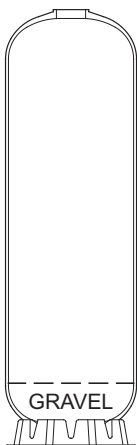

CARBON FILTERS

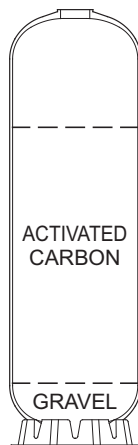

MULTI-MEDIA FILTERS

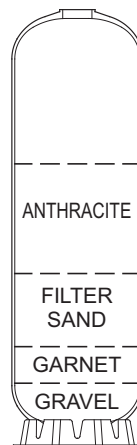

GREENSAND PLUS™ FILTERS



North Star Water Treatment Systems PROFESSIONAL ADVANTAGE COMMERCIAL SERIES WATER FILTERS – 2" VALVE

NOTE: All models shipped unassembled. Shipping weights are approximate.

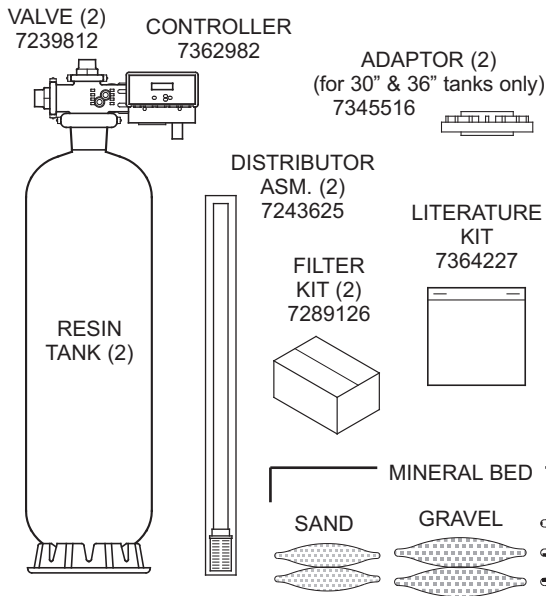

MODEL	SHIPPING WEIGHT	RESIN TANK	MINERAL BED
PA172XD	494#	17" x 58" P/N 7149994	see table below
PA242XD	680#	24" x 72" P/N 7298777	
PA172CD	830#	17" x 58" P/N 7149994	
PA242CD	1570#	24" x 72" P/N 7298777	
PA302CD	2320#	30" x 72" P/N 0403007	
PA362CD	2930#	36" x 72" P/N 0403006	
PA172MD	1110#	17" x 58" P/N 7149994	
PA242MD	2110#	24" x 72" P/N 7298777	
PA302MD	3200#	30" x 72" P/N 0403007	
PA172GD	1260#	17" x 58" P/N 7149994	
PA242GD	2320#	24" x 72" P/N 7298777	
PA302GD	3510#	30" x 72" P/N 0403007	



MODEL	GRAVEL 7124423		FILTER SAND 0993080		ACTIVATED CARBON 3424509	GREENSAND PLUS™ 7331101	ANTHRACITE 0993070		GARNET 0993090	
	lbs.	bags	lbs.	bags	1 cu. ft. bags	1/2 cu. ft. bags	lbs.	bags	lbs.	bags
PA172XD	200	4	–	–	–	–	–	–	–	–
PA242XD	300	6	–	–	–	–	–	–	–	–
PA172CD	200	4	–	–	8	–	–	–	–	–
PA242CD	300	6	–	–	20	–	–	–	–	–
PA302CD	500	10	–	–	30	–	–	–	–	–
PA362CD	600	12	–	–	40	–	–	–	–	–
PA172MD	200	4	200	4	–	–	312	6	100	2
PA242MD	300	6	500	10	–	–	624	12	300	6
PA302MD	500	10	700	14	–	–	1040	20	400	8
PA172GD	200	4	–	–	–	12	156	3	100	2
PA242GD	300	6	–	–	–	24	312	6	300	6
PA302GD	500	10	–	–	–	36	520	10	400	8

Greensand Plus™ is a trademark of Inversand Company.

BEDDING SEQUENCE OF GRAVEL & MINERALS

NOTE: Be sure distributor assembly is centered in tank before filling.

NO MEDIA
(GRAVEL ONLY) FILTERS

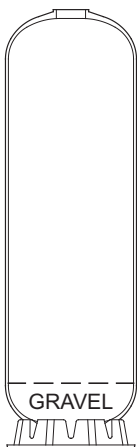

CARBON FILTERS



MULTI-MEDIA FILTERS



GREENSAND PLUS™
FILTERS



North Star Water Treatment Systems PROFESSIONAL ADVANTAGE COMMERCIAL SERIES WATER FILTERS – 2" VALVE

NOTE: All models shipped unassembled. Shipping weights are approximate.

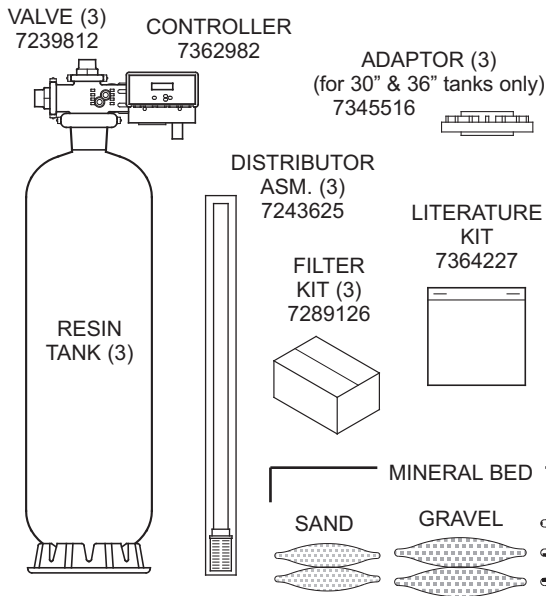

MODEL	SHIPPING WEIGHT	RESIN TANK	MINERAL BED
PA172XT	746#	17" x 58" P/N 7149994	see table below
PA242XT	1060#	24" x 72" P/N 7298777	
PA172CT	1250#	17" x 58" P/N 7149994	
PA242CT	2320#	24" x 72" P/N 7298777	
PA302CT	3500#	30" x 72" P/N 0403007	
PA362CT	4410#	36" x 72" P/N 0403006	
PA172MT	1660#	17" x 58" P/N 7149994	
PA242MT	3200#	24" x 72" P/N 7298777	
PA302MT	4823#	30" x 72" P/N 0403007	
PA172GT	1920#	17" x 58" P/N 7149994	
PA242GT	3480#	24" x 72" P/N 7298777	
PA302GT	5340#	30" x 72" P/N 0403007	

MODEL	GRAVEL 7124423		FILTER SAND 0993080		ACTIVATED CARBON 3424509	GREENSAND PLUS™ 7331101	ANTHRACITE 0993070		GARNET 0993090	
	lbs.	bags	lbs.	bags	1 cu. ft. bags	1/2 cu. ft. bags	lbs.	bags	lbs.	bags
PA172XT	300	6	–	–	–	–	–	–	–	–
PA242XT	450	9	–	–	–	–	–	–	–	–
PA172CT	300	6	–	–	12	–	–	–	–	–
PA242CT	450	9	–	–	30	–	–	–	–	–
PA302CT	750	15	–	–	45	–	–	–	–	–
PA362CT	900	18	–	–	60	–	–	–	–	–
PA172MT	300	6	300	6	–	–	468	9	150	3
PA242MT	450	9	750	15	–	–	936	18	450	9
PA302MT	750	15	1050	21	–	–	1560	30	600	12
PA172GT	300	6	–	–	–	18	234*	5*	150	3
PA242GT	450	9	–	–	–	36	468	9	450	9
PA302GT	750	15	–	–	–	54	780	15	600	12

Greensand Plus™ is a trademark of Inversand Company.

*4-1/2 of the 5 bags included are used.

BEDDING SEQUENCE OF GRAVEL & MINERALS

NOTE: Be sure distributor assembly is centered in tank before filling.

NO MEDIA
(GRAVEL ONLY) FILTERS

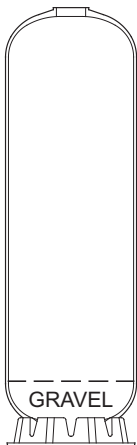

CARBON FILTERS



MULTI-MEDIA FILTERS



GREENSAND PLUS™
FILTERS



North Star Water Treatment Systems PROFESSIONAL ADVANTAGE COMMERCIAL SERIES WATER FILTERS – 2" VALVE

NOTE: All models shipped unassembled. Shipping weights are approximate.

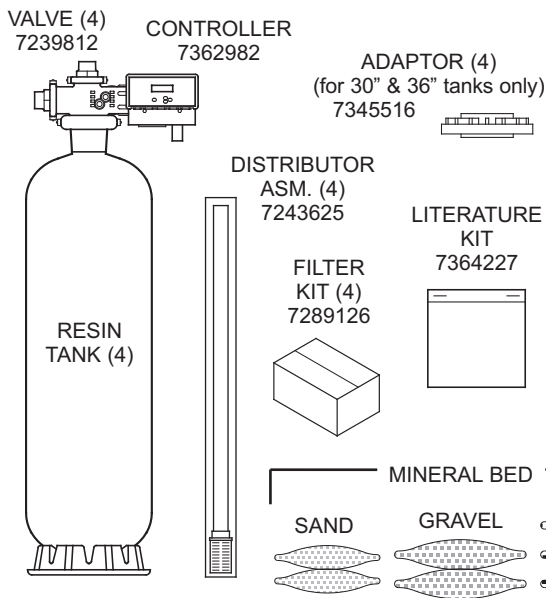

MODEL	SHIPPING WEIGHT	RESIN TANK	MINERAL BED
PA172XQ	988#	17" x 58" P/N 7149994	see table below
PA242XQ	1370#	24" x 72" P/N 7298777	
PA172CQ	2080#	17" x 58" P/N 7149994	
PA242CQ	3050#	24" x 72" P/N 7298777	
PA302CQ	4740#	30" x 72" P/N 0403007	
PA362CQ	5940#	36" x 72" P/N 0403006	
PA172MQ	2210#	17" x 58" P/N 7149994	
PA242MQ	4250#	24" x 72" P/N 7298777	
PA302MQ	6360#	30" x 72" P/N 0403007	
PA172GQ	2520#	17" x 58" P/N 7149994	
PA242GQ	4670#	24" x 72" P/N 7298777	
PA302GQ	6980#	30" x 72" P/N 0403007	

MODEL	GRAVEL 7124423		FILTER SAND 0993080		ACTIVATED CARBON 3424509	GREENSAND PLUS™ 7331101	ANTHRACITE 0993070		GARNET 0993090	
	lbs.	bags	lbs.	bags	1 cu. ft. bags	1/2 cu. ft. bags	lbs.	bags	lbs.	bags
PA172XQ	400	8	-	-	-	-	-	-	-	-
PA242XQ	600	12	-	-	-	-	-	-	-	-
PA172CQ	400	8	-	-	16	-	-	-	-	-
PA242CQ	600	12	-	-	40	-	-	-	-	-
PA302CQ	1000	20	-	-	60	-	-	-	-	-
PA362CQ	1200	24	-	-	80	-	-	-	-	-
PA172MQ	400	8	400	8	-	-	624	12	200	4
PA242MQ	600	12	1000	20	-	-	1248	24	600	12
PA302MQ	1000	20	1400	28	-	-	2080	40	800	16
PA172GQ	400	8	-	-	-	24	312	6	200	4
PA242GQ	600	12	-	-	-	48	624	12	600	12
PA302GQ	1000	20	-	-	-	72	1040	20	800	16

Greensand Plus™ is a trademark of Inversand Company.

BEDDING SEQUENCE OF GRAVEL & MINERALS

NOTE: Be sure distributor assembly is centered in tank before filling.

NO MEDIA
(GRAVEL ONLY) FILTERS

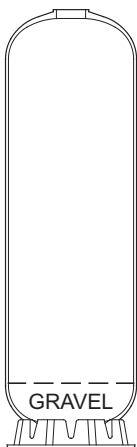

CARBON FILTERS



MULTI-MEDIA FILTERS



GREENSAND PLUS™
FILTERS



North Star Water Treatment Systems **PROFESSIONAL ADVANTAGE** **COMMERCIAL SERIES – 2” VALVE**

Media		
	Part Number	Weight (lbs.)
Resin	0502272	53
Gravel, Quartz	7124415	17
	7124423	50
Gravel, Medium	7127073	50
Anthracite	0993070	52
Garnet	0993090	50
Sand, Filter	0993080	50
Carbon, Activated	3424509	42
Greensand Plus™	7331101	44

Accessories	
	Part Number
External No Hard Water Shutoff Kit, 2” Valve, DC	7362225
Piston Plug, 2” Valve	7207750
Grip Ring for Above	7192769

Greensand Plus™ is a trademark of Inversand Company.