



NSCWC

This integrated water treatment system combines high-capacity resin with powerful carbon media, for soft and filtered water throughout the entire home. It provides fresh, filtered water at every faucet, while eliminating hard water stains, scale build-up, chlorine taste & odor and sediment, without the inconvenience or expense of changing filters.

FEATURES AND BENEFITS

- High-capacity 2-in-1 system softens and filters the water for your entire home
- Carbon filtration reduces sediment and chlorine taste & odor
- Self-cleaning sediment filter eliminates need to replace filters
- Utilizes AutoSense™ Technology to monitor your water usage to determine the optimal frequency of regeneration, minimizing salt and water use
- High-flow valve for optimal water pressure
- Low salt monitor flashes when the softener is low on salt, allowing you a few days to refill the tank
- Built-in tank light for low light conditions
- Ideal for any sized household
- Can be used with city or well water sources



REDUCES CHLORINE



REDUCES SEDIMENT



3 PPM CLEAR WATER IRON REMOVAL



ANY SIZED HOUSEHOLD

NO FILTERS TO REPLACE

Carbon media bed automatically cleans itself in regular intervals, eliminating the need for costly filter replacements.



CUSTOM BYPASS VALVE

Installation kit includes custom fit bypass valve. Connections out of water softener are standard 1" male NPT threads.



35,000 GRAIN WATER SOFTENER + WHOLE HOME FILTER

NSCWC

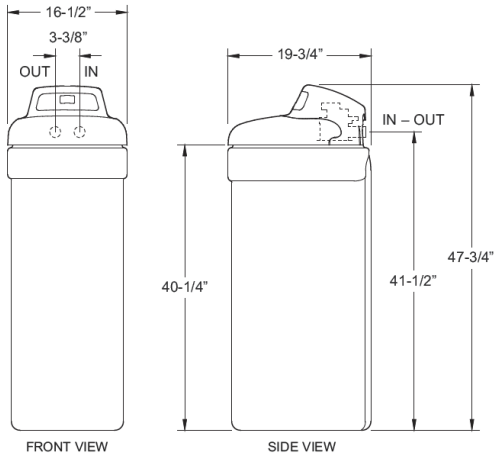

SPECIFICATIONS

Model Number	NSCWC
Part Number	NSCWC18
Household Size	All
Max. Capacity (grains)	35,600
Resin (cu. ft)	0.98
Standard Connection Size	1" NPT
Valve	3/4"
Rated Service Flow Rate (gpm)	8.0
Intermittent Flow Rate (gpm @ 30 psi drop)	17.1
Clear Water Iron Removal (ppm)	3
Electronic Demand	Yes
Max. Efficiency (grains removed per lb of salt)	4,780

WARRANTY

1 year parts	•
3 year electronic control board	•
10 year salt storage and mineral tank	•



System tested and certified by NSF International against NSF/ANSI Std. 42 for the reduction of chlorine taste and odor, and Std. 44 for hardness reduction, efficiency and the reduction of barium and radium 226/228, and certified to NSF/ANSI Std. 372.



System tested and certified by the Water Quality Association against CSA B483.1.

FOR MORE INFORMATION

EMAIL

info@northstarwater.com

VISIT

www.northstarwater.com

WARRANTY

Warrantor guarantees, to the original owner, that for a period of one (1) year from the date of purchase, all parts will be free from defects in materials and workmanship and will perform their normal functions. For a period of ten (10) years from the date of purchase, the salt storage tank and fiberglass mineral tank will not rust, corrode, leak, burst or in any other manner, fail to perform their proper functions. For a period of three (3) years from the date of purchase, the electronic control board and valve body will be free of defects in materials and workmanship and will perform their normal functions. If, during such respective period, a part proves to be defective, Warrantor will ship a replacement part directly to your home, without charge.